

1

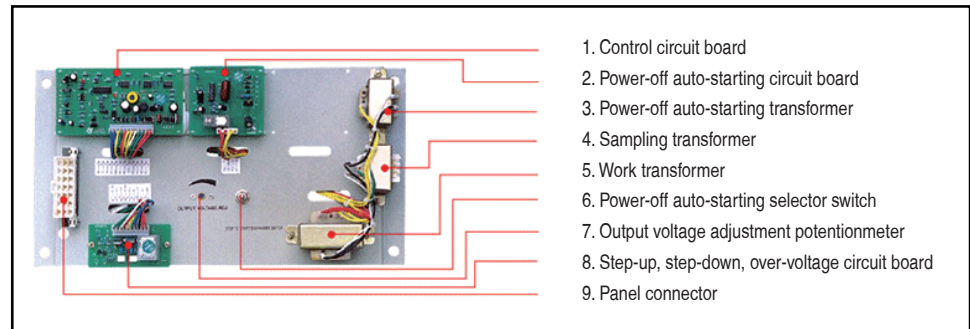

Three phase voltage stabilizers (split phase,SBW-F AVS)

20-60k/VA control board



80-120k/VA control board

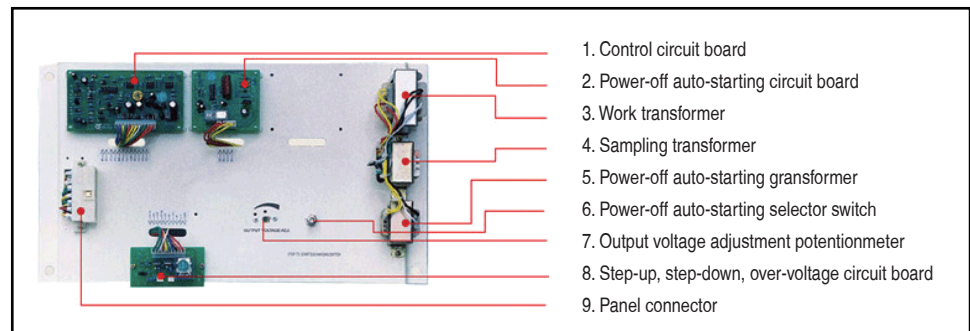

Control board of above 150k/VA(include 15)

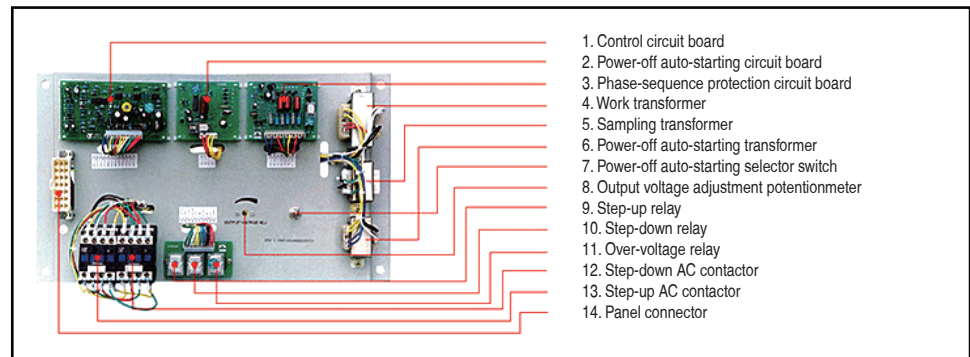

Model and specification

Model	Rated capability(KVA)	Output max current(A)	Size (mm) D*W*H	Cabinet Qty	Weight(kg)
SBW-F-20	20	30	680*1100*1320	One	480
SBW-F-30	30	45	380*1100*1320		500
SBW-F-50	50	76	380*1100*1320		652
SBW-F-100	100	152	800*1100*1420		847
SBW-F-150	150	227	1000*1350*1650		1360
SBW-F-180	180	273	1000*1350*1650		1680
SBW-F-200	200	303	1000*1350*1650		1410
SBW-F-225	225	341	1000*1350*1650		1470
SBW-F-250	250	379	1000*1350*1650		1490
SBW-F-300	300	455	1000*1350*1650		1700
SBW-F-400	400	606	1000*1350*1650	1760	